

# WASCO

SWITCHES & SENSORS

## ULTRA HIGH PURITY PRESSURE & VACUUM TRANSDUCERS

Wasco's Barracuda Series of Ultra High Purity (UHP) Sensors are designed for applications that require sensing of a corrosive media in demanding market applications. These transducers are ideally suited to sense gaseous or liquid media without introducing contamination to the process media.

This series is perfect for systems that require sensing of corrosive media in a high accuracy, tight tolerance application.

### BARRACUDA HIGHLIGHTS

We've designed these transducers for highly corrosive environments found in next-generation semiconductor processing equipment. The Barracuda series is rated for more than 10,000,000 application cycles. The Barracuda has materials available that meet or exceed SEMI F20 (UHP) with a critical pitting temperature performance of > 35°C. All sensors are helium leak tested to  $\leq 1 \times 10^{-9}$  std cc/sec Helium per SEMI F1.



### TYPICAL APPLICATIONS

- Gas Boxes
- IGS Gas Panels
- Gas Distribution Systems
- Valve Manifold Boxes
- Etch & Deposition Systems

### BARRACUDA PERFORMANCE CHART

Output	Supply Voltage	Stability	Accuracy	Proof Pressure	Burst Pressure
4-20 mA	12 to 32 VDC	$\pm 0.25\%$ BFSL Per Year	$\pm 0.25\%$ BFSL	2X Full Scale	3X Full Scale
0-5 VDC					
0.1-10.1 VDC					

## TECHNICAL SPECIFICATIONS

<b>Expected Lifetime</b>	≥10,000,000 cycles	<b>Pressure Port</b>	1/4" Male & Female Face Seal
<b>Pressure Range</b>	-1 Bar up to +3000 PSIG	<b>Electrical Connection</b>	M12 Connector
<b>Operating Temperatures</b>	-20 to 85°C	<b>Media Compatibility</b>	Compatible with 316L, Semi F20 UHP Grade
<b>Zero Offset/ Span Tolerance</b>	±2.0% FS	<b>Fitting</b>	316L, Semi F20 UHP Grade
<b>Current Consumption</b>	< 12 mA Voltage (Typ.)	<b>Internal Surface Finish</b>	5 Ra

## BARRACUDA DIMENSIONS

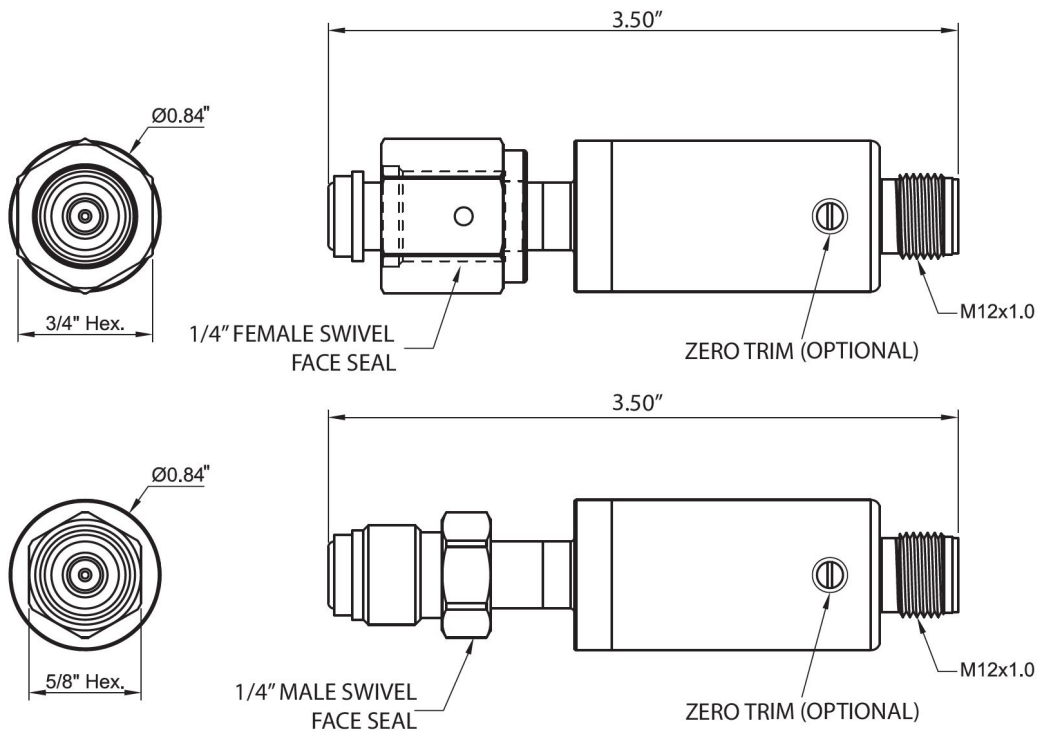

We understand how difficult the specifying process is, but we believe it shouldn't be so confusing. Wasco has specified over 6000 unique pressure sensors for thousands of customers since 1963.

**Find your solution today by filling out our [worksheet](#).**

\*Information contained in this document is for reference only. Actual product specifications will be provided on an engineering drawing.

Released November, 2021



SCAN ME

[www.wascoinc.com](http://www.wascoinc.com)  
[sales@wascoinc.com](mailto:sales@wascoinc.com)  
 (800) 500-9272