

WASCO

SWITCHES & SENSORS

UHP160 ULTRA HIGH PURITY SWITCH SERIES

Industry leading customers have depended upon the reliability and performance of the UHP160 Series since 1989. This series features an all stainless steel sensor in addition to an all welded construction. The UHP160 Series incorporates Wasco's proprietary manufacturing method which eliminates all leak paths.

This series is a perfect switch to handle corrosive media with high accuracy and tight tolerance.



UHP160 HIGHLIGHTS

We've designed these switches for ultra high purity applications such as semiconductor equipment. The UHP160 Series does not contain any elastomer or an O-ring. All switches are helium leak tested to $\leq 1 \times 10^{-9}$ std cc/sec per SEMI F1. The UHP160 Series is manufactured and packaged inside a Class 100 cleanroom.

TYPICAL APPLICATIONS

- Gas Boxes
- Ozone Systems
- Gas Distribution Systems
- Semiconductor Equipment
- Medical Equipment

UHP160 SERIES PERFORMANCE CHART

Sensor	Max. System Pressure*	Set Point Range*	Set Point Tolerance	Typical Reset Band
3	30.0	1.6 - 25.0	± 1.2	1.0 - 4.6
5	30.0	6.0 - 29.5	± 4.0	1.4 - 7.6

All measurements = inHg
* Other ranges available

MATERIAL SPECS

	Wetted Components
Fitting	316L SS
Diaphragm	17-7PH SS and 316L SS

TECHNICAL SPECS

Life Cycle	≥1,000,000 cycles
Ingress Protection	IP67
Leak Rate	100% Helium Leak Tested to $\leq 1 \times 10^{-9}$ std cc/sec
Operating Temp	-65° to 225°F -54° to 107°C

UHP160 DIMENSIONS

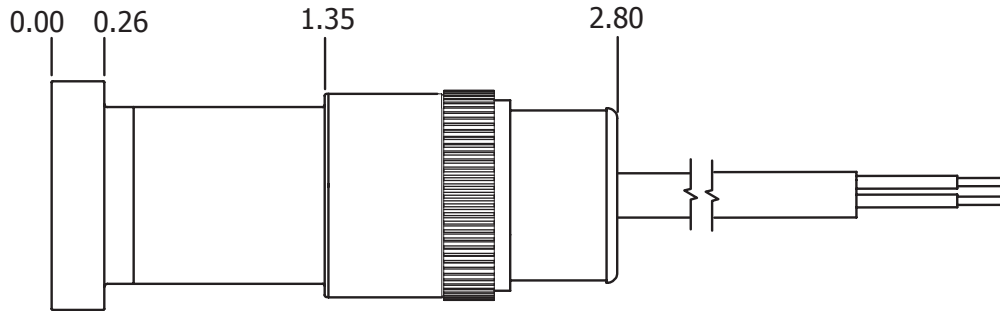

Typical UHP 160 with IGS surface mount (other configurations available)

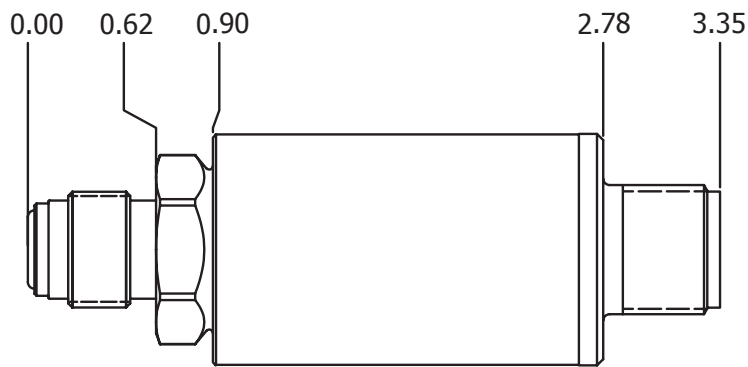

Typical UHP 160 with 1/4" male face seal (other configurations available)

We understand how difficult the specifying process is, but we believe it shouldn't be so confusing. Wasco has specified over 6000 unique pressure sensors for thousands of customers since 1963.

Find your solution today by filling out our [worksheet](#).

*Information contained in this document is for reference only.
Actual product specifications will be provided on an engineering drawing.
Released August, 2023



SCAN ME

www.wascoinc.com
sales@wascoinc.com
(800) 500-9272